

# USER MANUAL

## Speaksee Microphone Kit



Information in this document may change without notice.

©Speaksee. All rights reserved.

# CONTENTS

<b>PARTS OVERVIEW</b>	<b>4</b>
In the box of the Microphone Kit	4
Sticker on the box	5
Speaksee Microphones	5
Charging dock	6
Accessories for charging	7
<b>INSTALLATION</b>	<b>8</b>
Follow the steps of the Quickstart Card	8
Follow the steps of the Speaksee App	9
<b>DAILY USE</b>	<b>15</b>
Turn on the Microphone Kit	16
Wear the microphones	18
Transcribe conversations	19
Recognising the battery status	19
Turning off the Microphone Kit	21
Charging the Microphone Kit	22
<b>Software updates</b>	<b>22</b>
App updates	23
<b>ADJUSTING SETTINGS</b>	<b>24</b>
Adjust legibility	24
Translation	25
Adding additional Wi-Fi networks	26
<b>TROUBLESHOOTING</b>	<b>29</b>
Legend of charging dock lights	29
Legend of the microphone light	31
Legend of power button operation	34
Sharing of user logs	35
Reset to factory settings	38
<b>TECHNICAL SPECIFICATIONS</b>	<b>39</b>
<b>LEGAL INFORMATION</b>	<b>39</b>
Privacy policy	40
Regulatory information	40
Important advice	41
Safety precautions	42

## CONTACT DETAILS

43

## PARTS OVERVIEW

### In the box of the Microphone Kit



The Speaksee Microphone Kit includes the following parts and accessories:

- 1 x Charging dock
- 3 x Microphone
- 9 x Colour pucks
- 3 x Neck straps
- 1 x International adaptor
- 1 x USB-C cable
- 1 x Carry case

Along with the following printed documentation:

- Quickstart Card
- User Guide
- Legal Information Card

Optional accessories:

- 1 x Wi-Fi Hotspot



## Sticker on the box

The sticker on the box contains information with regard to your Microphone Kit.

- MAC (LAN1): refers to the Wi-Fi MAC address
- MAC (LAN2): refers to the Ethernet MAC address
- SN: is the unique serial number of your Microphone Kit, this is the same code as printed on the back of your charging dock.



## Speaksee Microphones

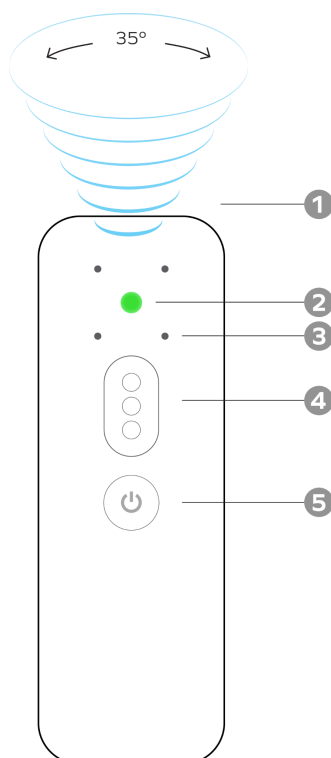

### 1. Focused speech detection

To pick up the voice of the person wearing it.

### 2. Light

Indicating the microphone status. See the [legend of the microphone light](#) for a full overview.

### 3. Microphone receivers

To listen and transcribe what is being said in real-time

### 4. Colour puck

Change the colour puck to suit your style or usage situation. Nine different colours are provided with each Microphone Kit.

Please note: Changing speaker colours within the Speaksee App is not yet supported.

### 5. Power button

After switching on the charging dock, switch on the microphones by pressing this power button.

## Charging dock

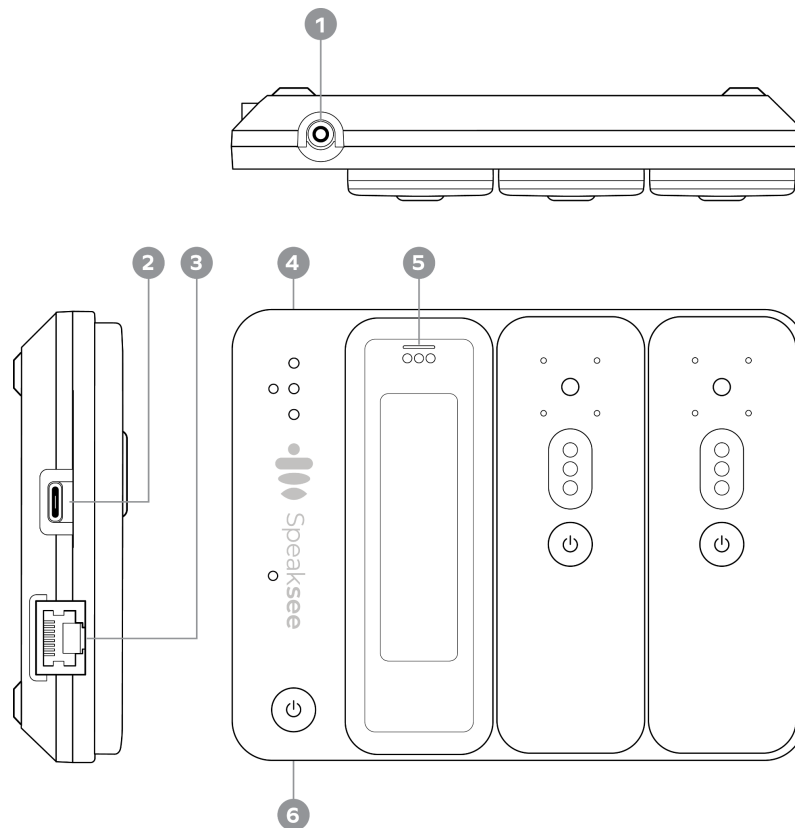

### 1. Audio jack port

Connect a device from which you want to subtitle the audio. Think of your smartphone or your TV. Connect it with a 3.5 mm audio cable.

NOTE: this feature is not fully supported yet for all setups.

### 2. USB-C charge port

Use this port to charge your Microphone Kit.

### 3. Ethernet port

Connect via cable internet with this port, alternative to Wi-Fi.  
NOTE: this feature is not fully supported yet for all setups.

### 4. Lights

To indicate the charging dock status. See the [legend of charging dock lights](#) for a full overview.

### 5. Charging pins

To connect the microphones to the dock to charge them.

### 6. Power button

Press this to turn on the Speaksee dock. Then turn on the microphones separately.

## Accessories for charging

For charging the Microphone Kit, use only the supplied adapter and cable.

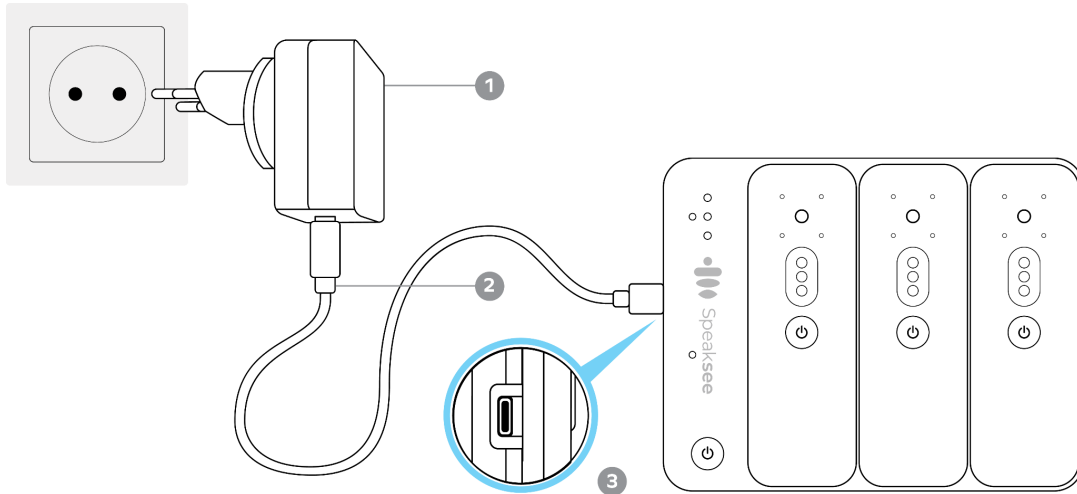

### 1. International adaptor

Change the adaptor head to suit your power outlet.

### 2. USB-C cable

To connect the adaptor to the charging dock.

### 3. USB-C port

Plug the USB-C cable into this port of the charging dock.

# INSTALLATION

## Follow the steps of the Quickstart Card

With your Microphone Kit, a paper printed Quickstart card can be found in the inside pocket of your carry case. It looks like this:

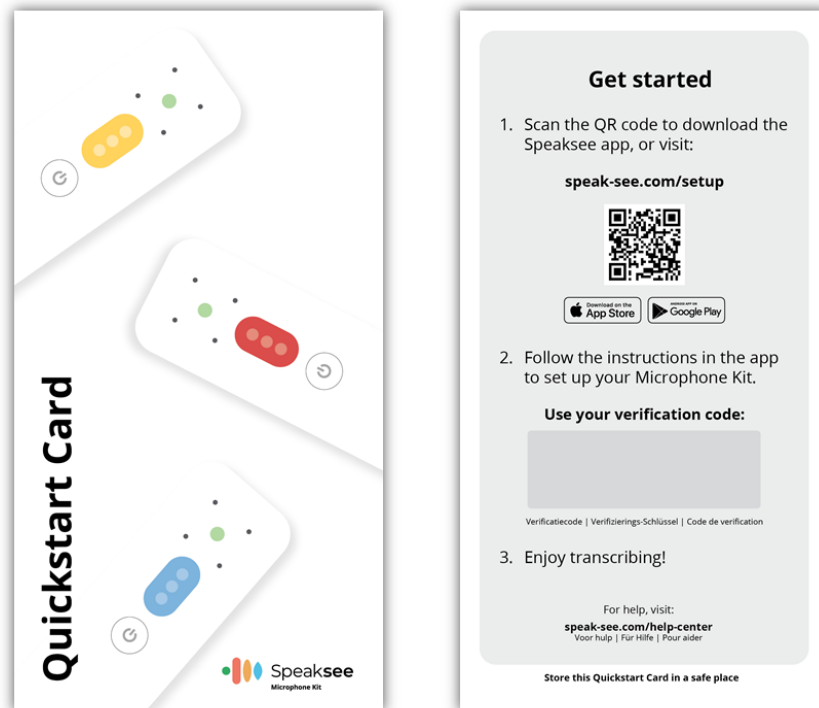

Example shown of Production run 2021

Get started by following these 3 steps and use the Verification code to onboard your device:

### 1. Install the Speaksee app

Scan the QR code as shown on the Quickstart Card to download the Speaksee app or visit: [speak-see.com/setup](https://speak-see.com/setup)

### 2. Set-up your Microphone Kit

Follow the instructions in the app to set-up your Microphone Kit. You will be prompted to use your verification code as printed on your Quickstart Card.

Please note: The verification code can only be used once. If you want to use Speaksee on an additional device, make sure to login with the same account.

### 3. Enjoy transcribing!



## Follow the steps of the Speaksee App

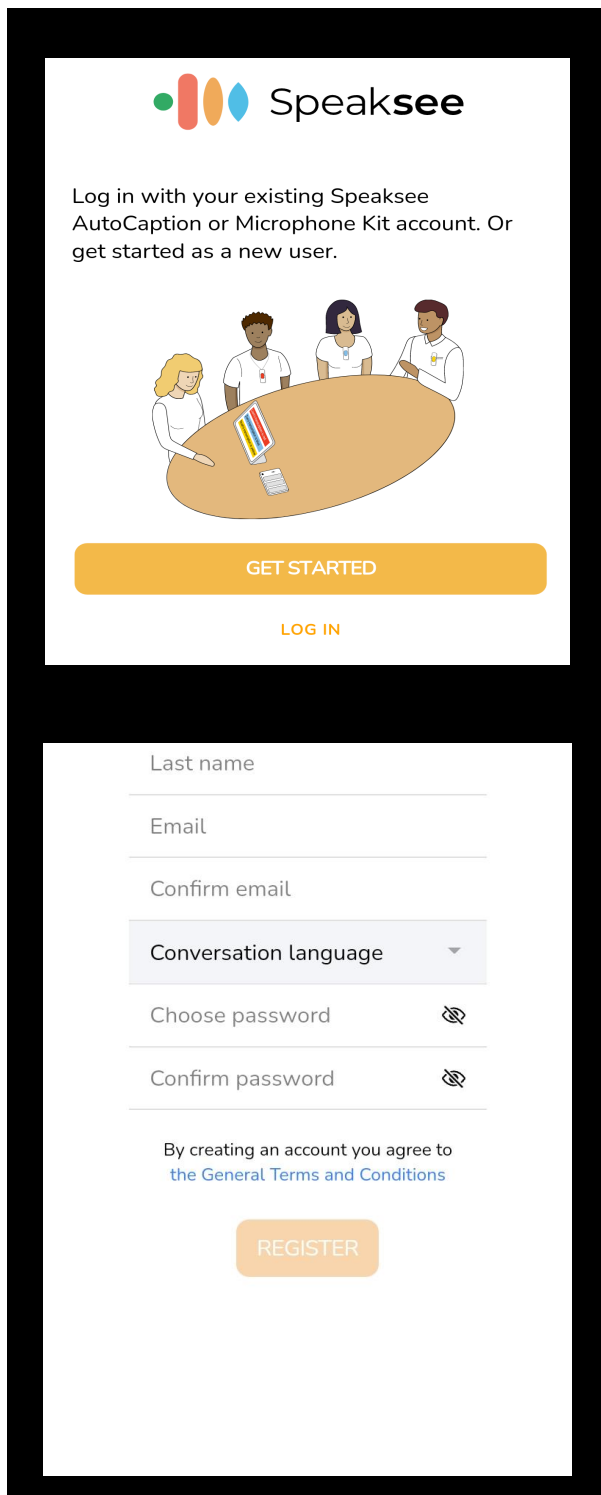

The image shows two screenshots from the Speaksee app. The top screenshot is the login screen, featuring the Speaksee logo at the top. Below the logo, it says "Log in with your existing Speaksee AutoCaption or Microphone Kit account. Or get started as a new user." There is an illustration of four people around a table. At the bottom, there are two buttons: a large orange "GET STARTED" button and a smaller "LOG IN" button. The bottom screenshot is the registration form. It has input fields for "Last name", "Email", and "Confirm email". There is a dropdown menu for "Conversation language". Below that are fields for "Choose password" and "Confirm password", each with an eye icon to toggle visibility. At the bottom, there is a link for "the General Terms and Conditions" and a large orange "REGISTER" button.

### 1. Creating an account

If you do not have a Speaksee account yet, press the "Get started" button. Do you already have an account? Then you can press "Login". Continue with step 3. Do you already have an account for Speaksee AutoCaption? Then you can login with the same credentials.

Fill in the complete form to be able to create your Speaksee account.

**Please note:** Special characters are not allowed in the name fields.

For the conversation language, you can select the language of the audio that the microphones are receiving. Later on we will add a language switcher inside the application.

Choose your own password to be able to login to your Speaksee account, this is **NOT** the unique verification code on your quick start card.

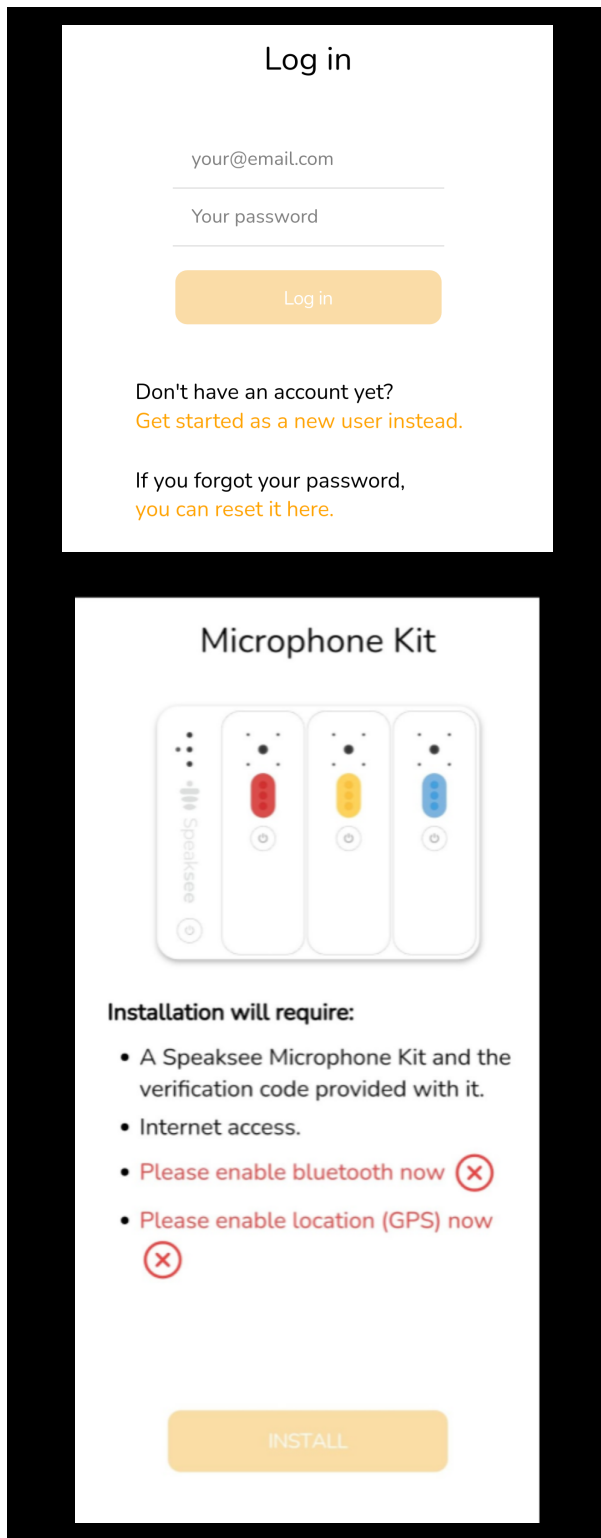

## 2. Verifying your account

After creating your account, you will receive an email to verify your account. Click on the link in the email and your account will be verified. After clicking on the link, you can return to the app and login with your Speaksee account.

## 3. Turn on Bluetooth (and location)

In order to connect the Microphone Kit to your phone or tablet, Bluetooth must be enabled. **Note: Android users also need to enable their location.**

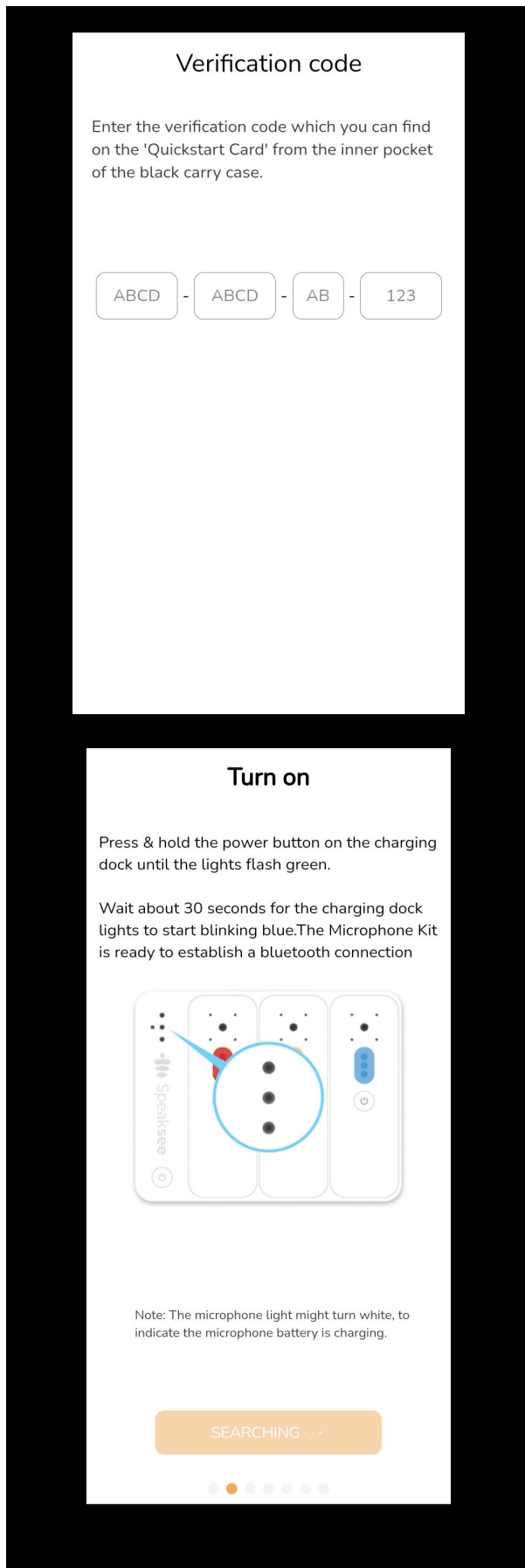

#### 4. Verifying your Microphone Kit

Fill in the unique verification code delivered with your Speaksee Microphone Kit. You can find the verification code on the Quickstart Card in the inner pocket of your Speaksee carry case.

Please note: The verification code can only be used once. If you want to use Speaksee on an additional device, make sure to login with the same account.

#### 5. Turning on the Microphone Kit

Click the power button of the charging dock to turn the Microphone Kit on. You will see that all 3 lights turn green and start blinking. If the lights start blinking blue, the Microphone Kit is ready to establish a bluetooth connection. You can press "Next".

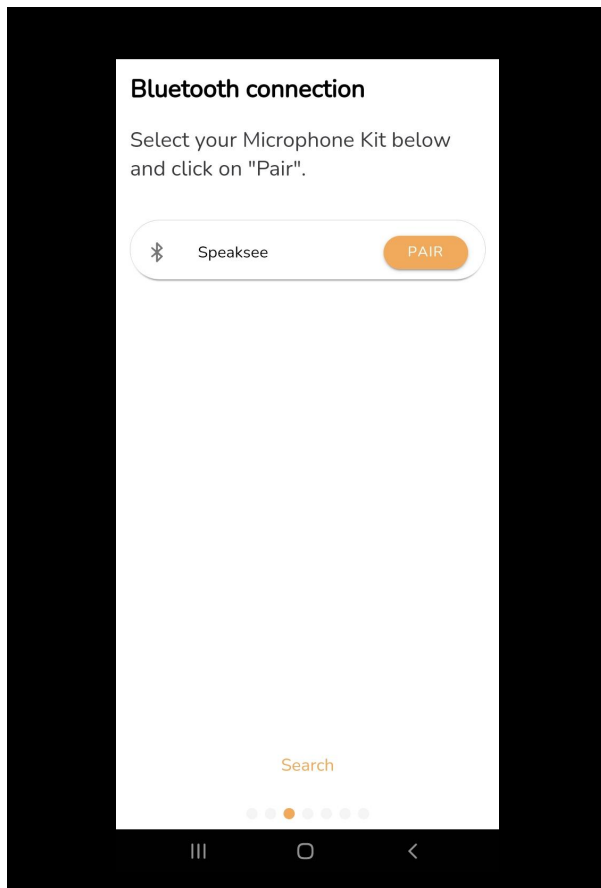

## 6. Pairing the Microphone Kit with your Phone

The app is scanning to set up a connection between your phone and the Microphone Kit. Once the Microphone Kit under the name Speaksee is found, you can press "Pair". You will now be able to connect a Wi-Fi network on the next page.



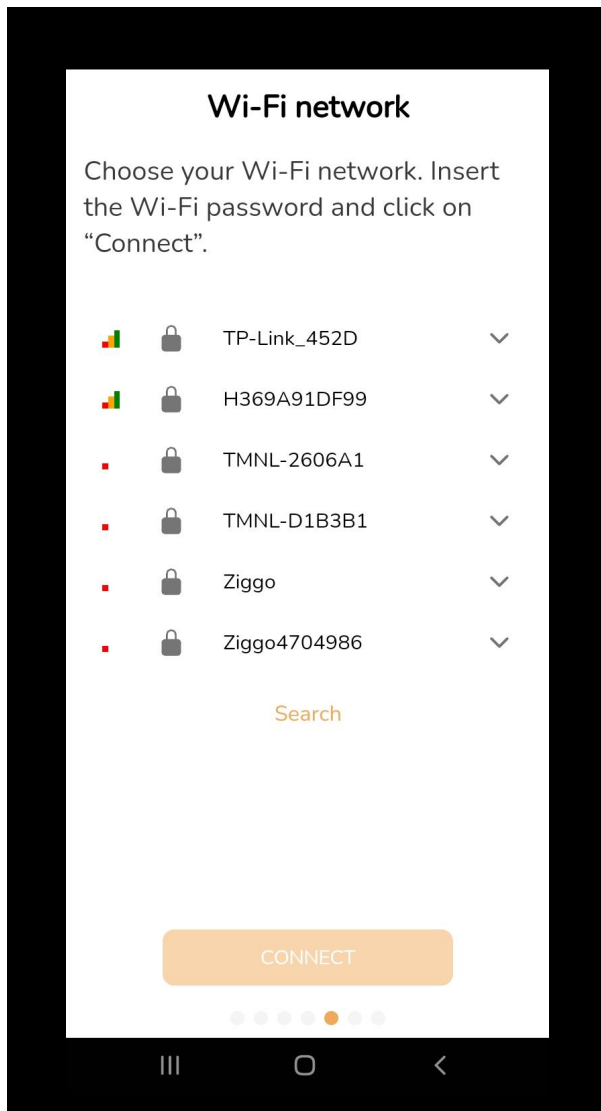

## 7. Setting up Wi-Fi

Select the Wi-Fi network you would like to connect to the Speaksee Microphone Kit. Fill in the correct Wi-Fi credentials and press "Connect". Is the app unable to find your desired network? Please press "Scan again". If the app is still unable to find your network after 3 tries, please contact our support team.



## 8. Removing the protective stickers

Please remove all 3 protective stickers from your Microphones before you start using your Microphone Kit. Once this is done, you can press "Finish". You have now successfully installed your Microphone Kit!

## 9. Ready for use

You are now ready to use your Speaksee Microphone kit. Please move to the next page for the instructions on how to use your Microphone Kit.

## DAILY USE

The Speaksee Microphone Kit transcribes what people are saying in real time, even in groups and when there is background noise.

Use the Speaksee app on your smartphone, tablet or laptop and view who says what. The speech picked up by each microphone is displayed in a different colour.

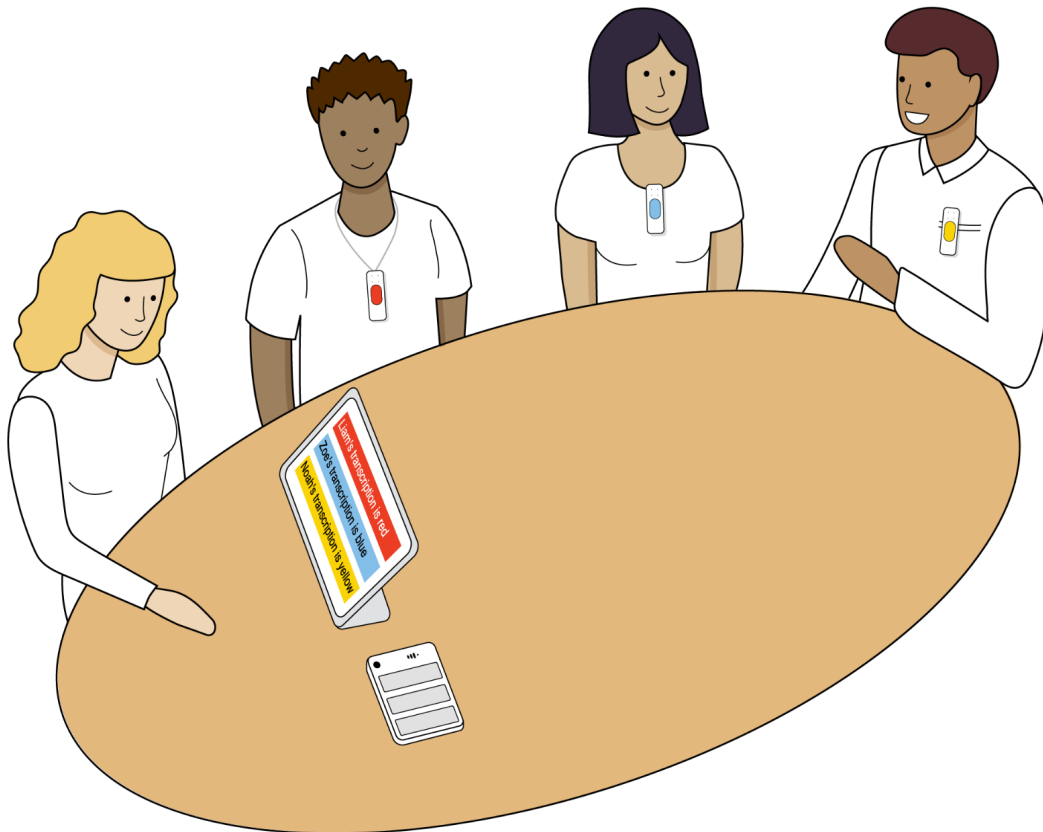

### **Your conversations are secure**

Feel free to use your Microphone Kit in any setting. Your transcriptions are hardware and software encrypted. The security of the Microphone Kit was also put to the test by a team of KPN IT experts. We passed this test.

## Turn on the Microphone Kit

At first use, set up your Microphone Kit following the steps as described in the chapter [“Installation”](#). For each use, always turn on the charging dock first, then lift each microphone you wish to use off the dock and turn them on individually.

### 1. Turn on the Charging dock

Before switching on the microphones, turn on the charging dock by holding the power button for 1 second.

The 3 lights start blinking green, to indicate that the device is turning on. Boot-up takes about 30 seconds, during which it checks for software updates and tries to connect to the internet.

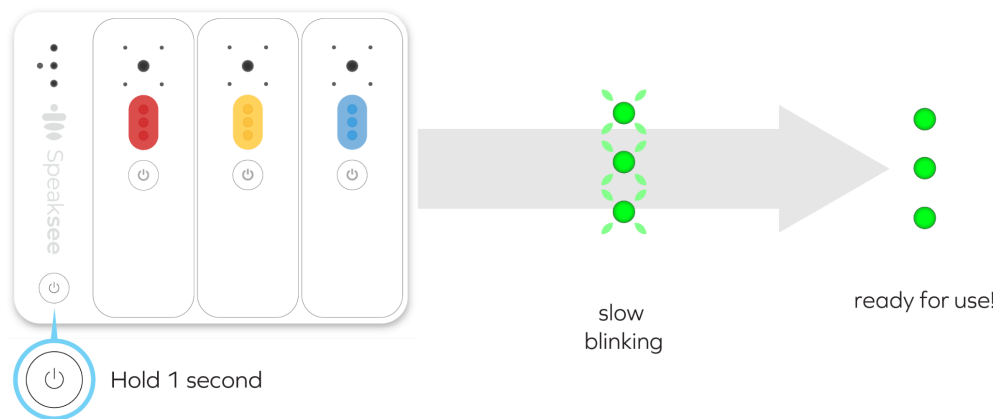

**Once the lights light up green continuously, the charging dock is ready for use. You can now take out the microphones.**

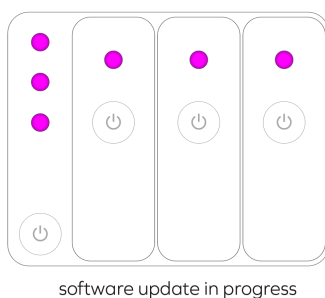

NOTE: Upon turning on the charging dock a software update might happen. A software update is identified by 3 fuchsia lights, please read the section on [Software updates](#) for a detailed explanation.



## 2. Turn on the microphones

Once the charging dock is on, turn on each microphone by lifting it from the dock and holding the power button for 1 second.

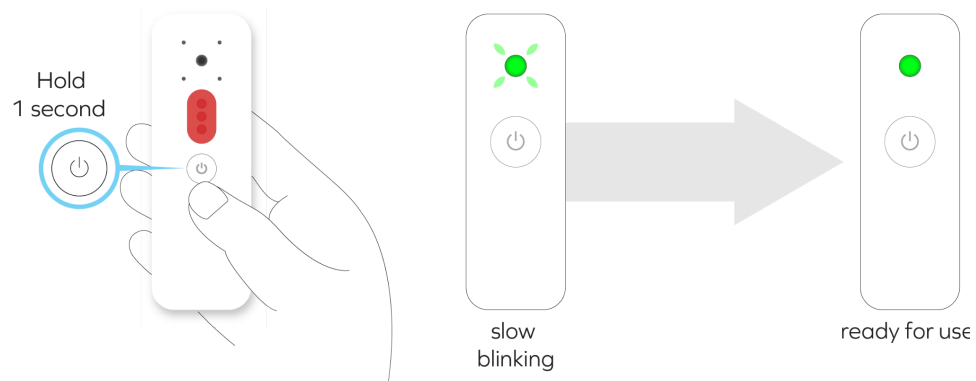

The light will blink green, to indicate 'booting-up'. This takes about 5 seconds. Once the microphone light is steady green, the microphone is ready for usage. You can now hand out the microphones to each speaker.

## Wear the microphones

Each speaker should wear a microphone to transcribe a conversation. To pick up the voice of the person wearing it, it is important that the microphone points upwards towards the mouth of the speaker. Also, the light should be visible, facing forward.

### Clip

Use the clip for shirts that have a top pocket or a low neckline.

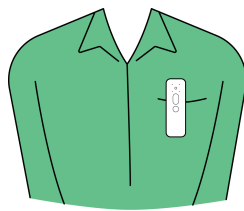

Clipped to pocket

Open the clip by applying light pressure and attach to clothing as desired.

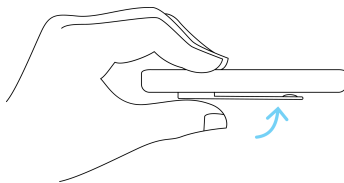

### Neck strap

For all other clothing, attach the neck strap to the microphone by clipping the magnetic charm to the back of the microphone.

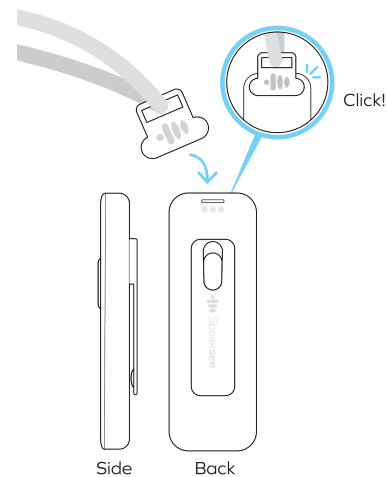

### Correct wear



Clipped to low neckline shirt

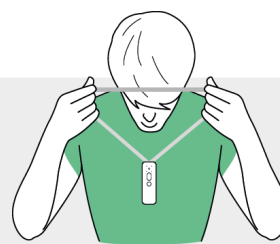

Neck strap for high neck shirts

### Incorrect wear



Clipped into shirt on an angle



Clipped onto high neck shirt

## Transcribe conversations

The accuracy is best when everyone in the conversation articulates clearly and speaks audibly (loud enough). It is best to inform all conversation participants about this beforehand.

### In the app

Once the Microphone Kit is turned on you can press the “Start transcribing” button in the app. You can then select the Microphone Kit in the popup. Every speaker can now start talking and the transcripts will appear in the app.

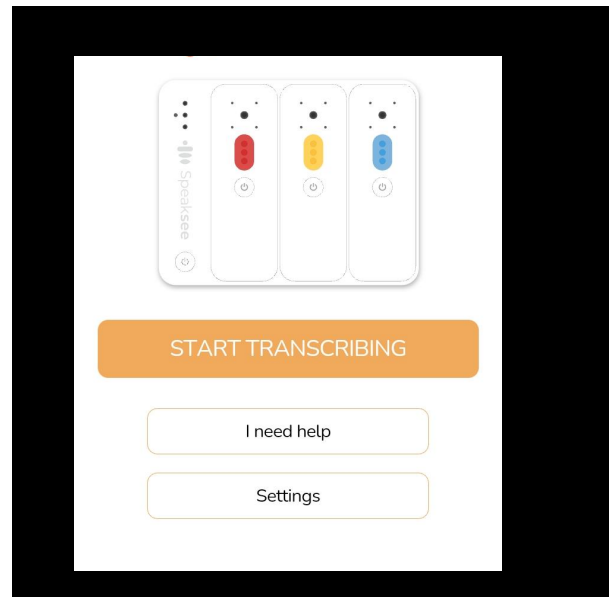

### Via web browser

For transcriptions via the web browser, navigate to [speak-see.com/web](https://speak-see.com/web). Login with your Speaksee account and select the Microphone Kit you would like to use. Every speaker can now start talking and the transcripts will appear in the app.

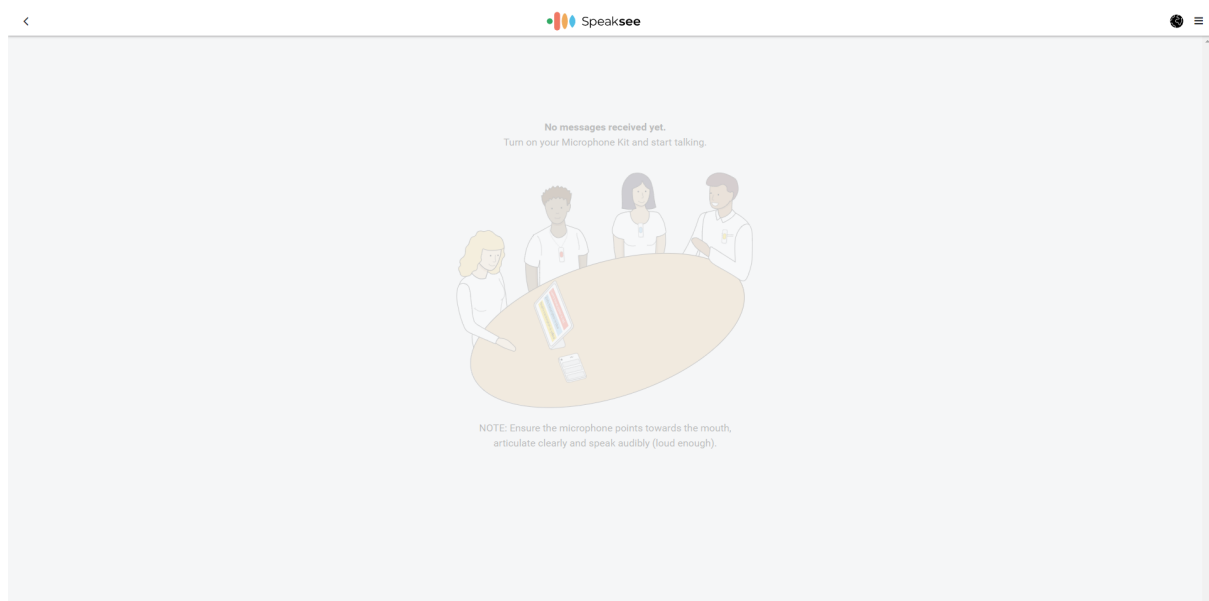

## Recognising the battery status

During use, the battery of the Microphone Kit slowly runs out. It is good to be aware of this, so that you can recognise in time when the Microphone Kit needs to be charged.

Average operating time for each microphone is 1 hour and 45 minutes. Meaning a 100% full battery allows you to have a 1 hour and 45 minute conversation until the microphone switches off.

### Full:

As long as the lights are green during use, the Microphone Kit is sufficiently charged.

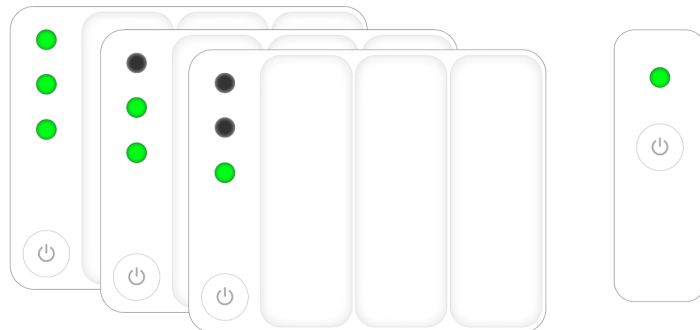

battery sufficiently charged for use

### Almost empty:

If the battery is low, the light will alternately flash green and red.

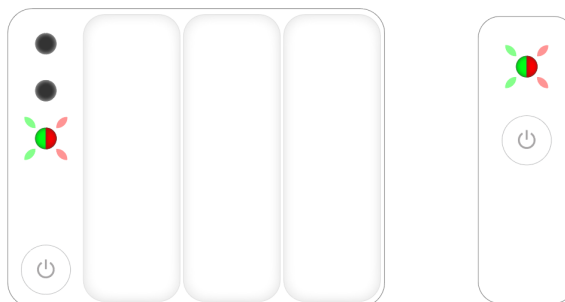

NOTE: battery almost empty!

### Battery too low to use:

In case no charging action is taken, the Microphone Kit will automatically switch off. This is indicated by the light(s) flashing red 10 times.



automatic turn off due to low battery



# Turning off the Microphone Kit

## 1. The Microphones

Turn off the microphones by simply placing the microphones back in the charging dock. The microphones will start charging or turn off when the battery is full.

## 2. The charging dock

Press and hold the charging dock's power button for 1 second to switch it off. The lights will flash red once. If the charging station is not connected to the charger, all lights are out.

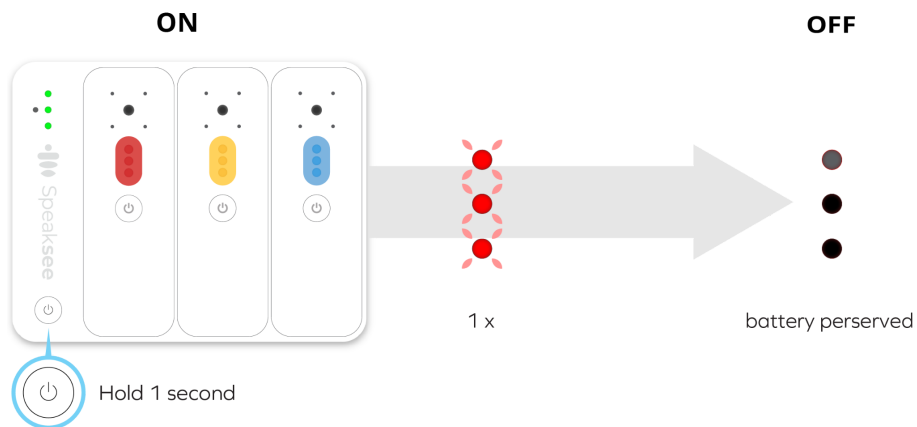

## Charging the Microphone Kit

During charging, the lights are white to indicate the battery charging status.

NOTE: The Microphone Kit cannot charge in full off mode.

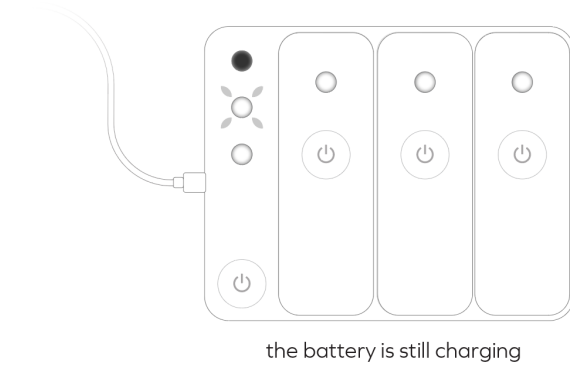

### Charging:

When the charging dock is charging, one of the lights flashes in white.

The charging of the microphones is indicated by the lights being steady white.

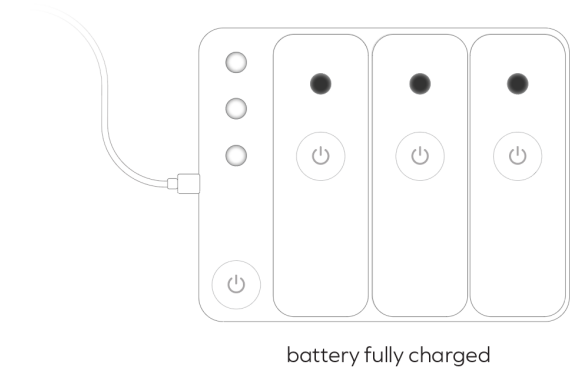

### Battery is full:

The charging dock is fully charged when all 3 lights light up white continuously.

When the microphones are fully charged, the lights are out while in the charging dock.

### Charging the charging dock

To charge the desktop charger, connect the USB-C cable and adapter as described in the chapter [accessories for charging](#).

TIP: The charging dock can also be charged while in use!

CAUTION: Do not leave the Microphone Kit in an ambient temperature higher than 35°C.

### Charging the Microphones

The microphones are automatically charged when placed back in the charging dock.

NOTE: The microphones will not charge if the battery level on the charging dock is too low

## Software updates

The software of your Microphone Kit will be kept up-to-date automatically. An update can happen during boot-up, indicated by the charging dock lights turning fuchsia. In that case: leave the microphones docked, do not press the power button and connect a charger when needed. An update can take 5 - 60 minutes.

We currently release software updates every 1 or 2 months. We inform our users on everything they need to know about the update in advance via email.

Below you will find an overview of the updating process. First, the lights on the charging dock will be steady fuchsia. After a few minutes, the microphones will also turn fuchsia 1 by 1, indicating that the microphones are updating. Once the update is finished the Microphone Kit will reboot and the lights become green.

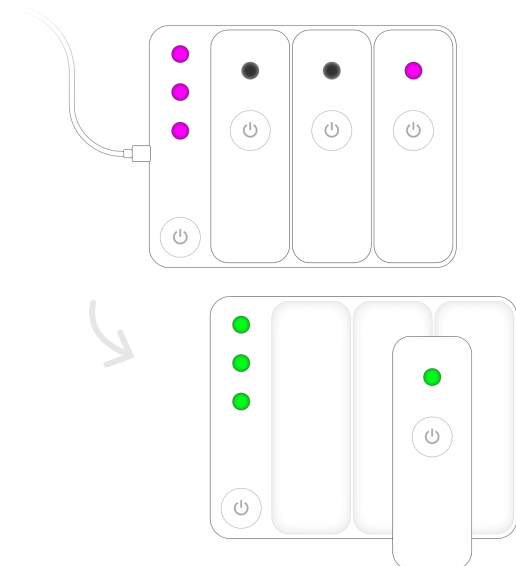

The microphones update 1 by 1.  
When finished the lights turn green.

## App updates

Make sure to keep our app updated to the most recent version. We're always improving!

# ADJUSTING SETTINGS

## Adjust legibility

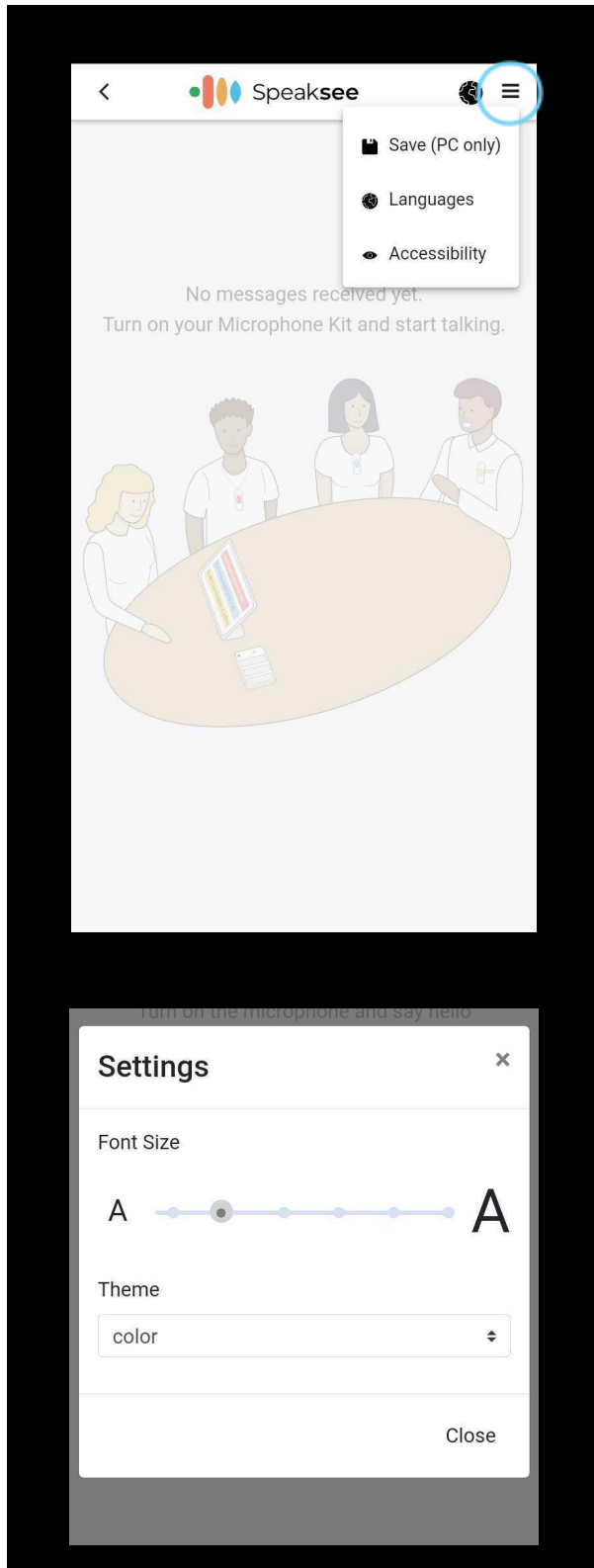

### Font size & colour theme

Press the settings wheel icon in the top right corner of the screen. This will open the settings menu. Here you can select "Accessibility".

Drag the font size bar to the left or right to be able to make the text of the transcripts smaller or bigger.

Select a theme to style your transcript screen to your own preferences. You can choose between "Color" and "Glow".

## Translation

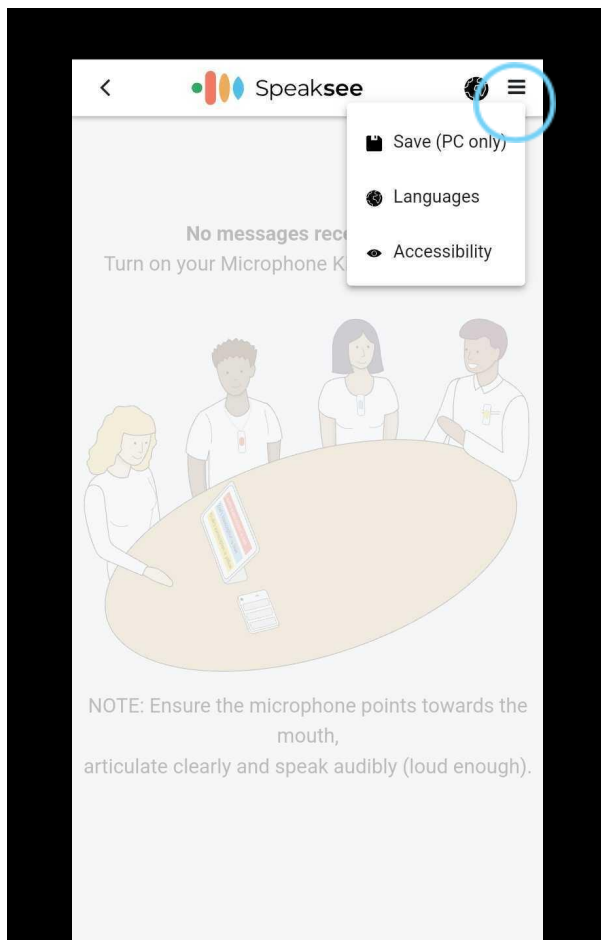

Press the menu icon in the top right corner of the screen. This will open the settings menu. Here you can select "Languages".

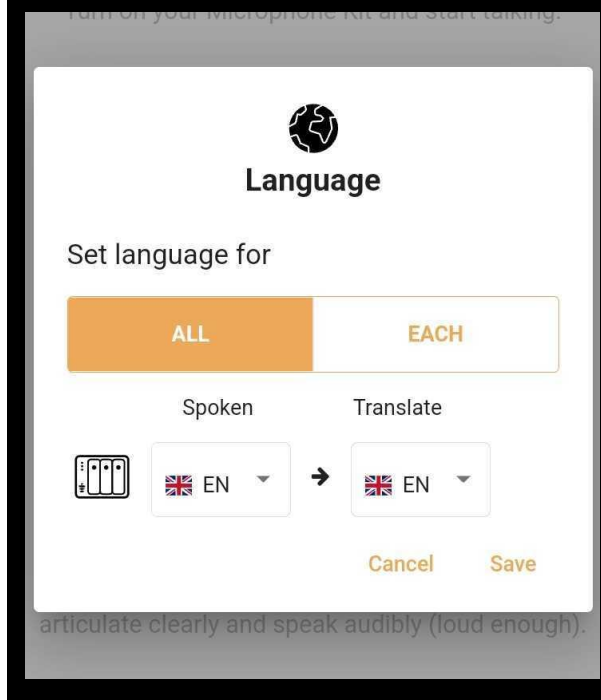

In this menu you can select both the input and the output language of the spoken words. If you do not want the output text to be translated, then keep the language the same as the spoken language.

On the each tab, you can set the specific input and output language for each microphone separately.

## Adding additional Wi-Fi networks

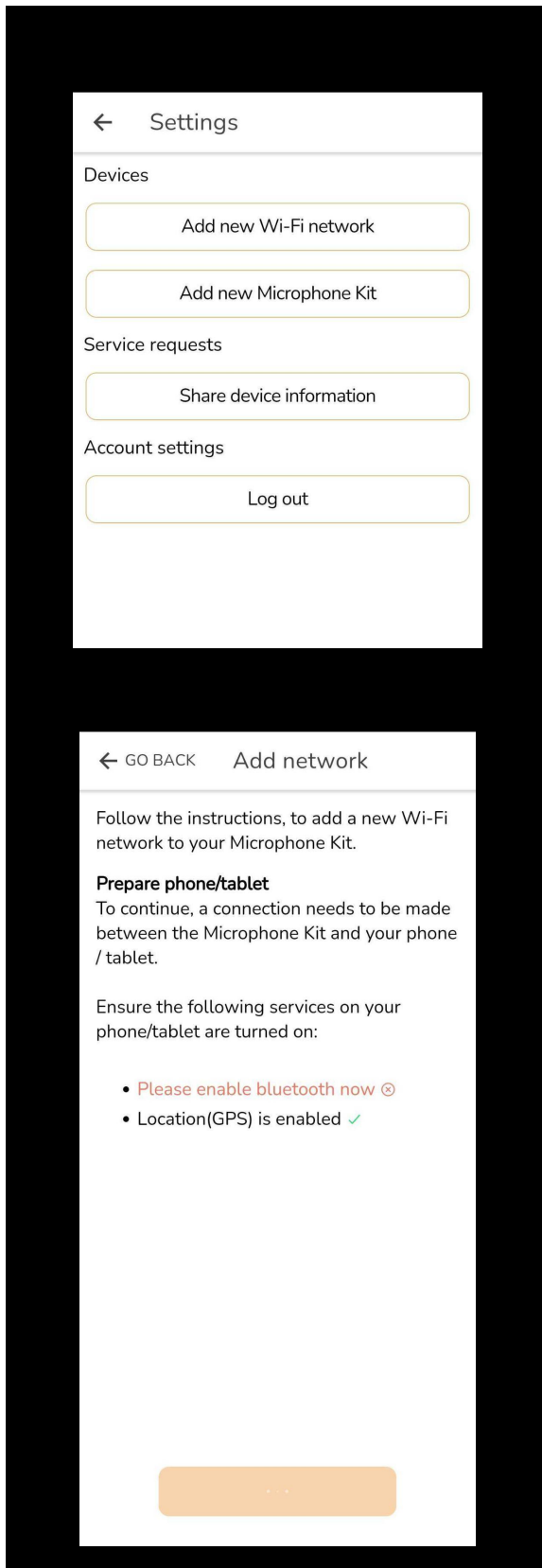

Press the settings button in the menu of the Speaksee app and then press "Add new Wi-Fi network".

In order to connect the Microphone Kit to your phone or tablet, Bluetooth must be enabled. **Note: Android users also need to enable their location.**



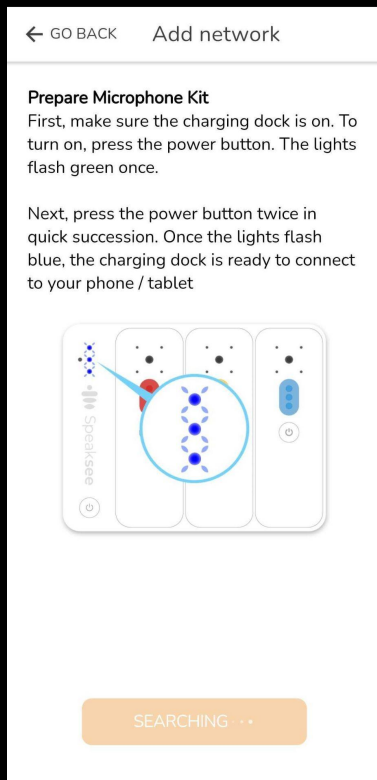

To add a new Wi-Fi network, the charging dock must be put manually into Bluetooth mode. First turn on the charging dock. The lights start blinking green. Then double press the on/off button. You will see 3 blue blinking lights. You can now press next.

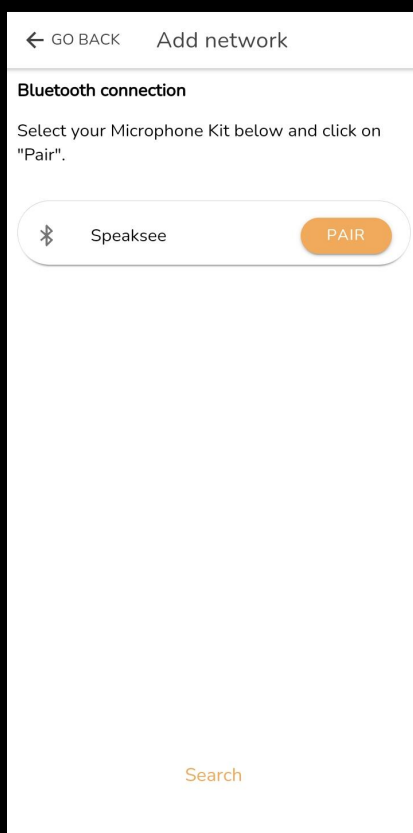

When your Microphone Kit is found in the app, you can press "pair". On the next screen, you can select a Wi-Fi network.

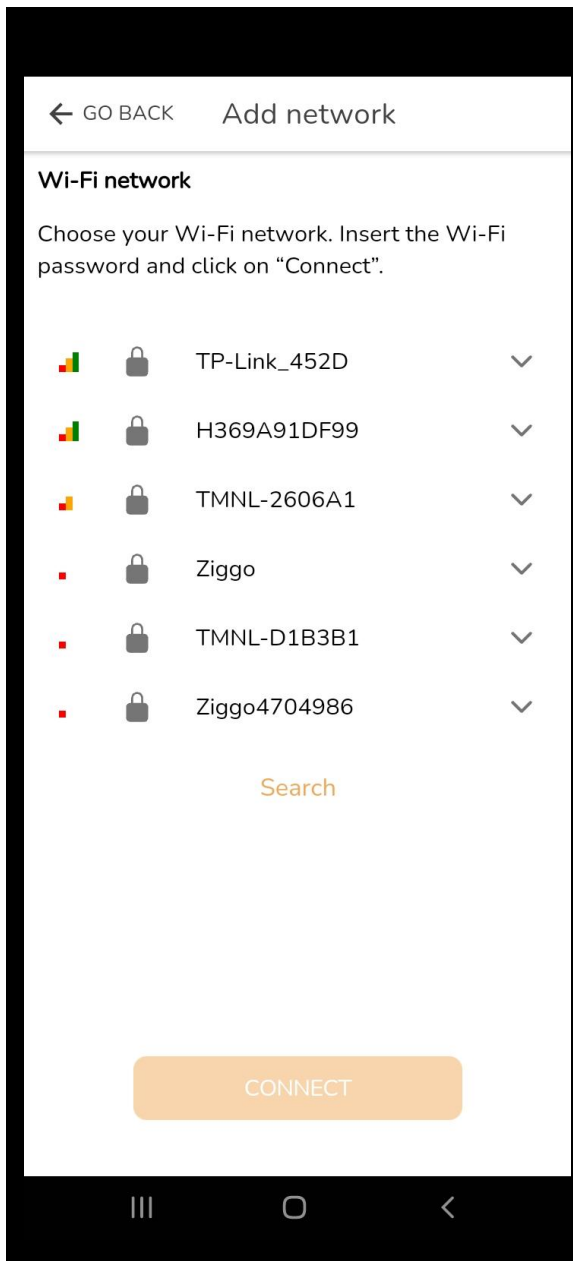



Select the Wi-Fi network you want to connect to the Speaksee Microphone Kit. Fill in the correct Wi-Fi credentials and press "Connect". Can't find the desired network? Then press "Search". If after 3 attempts the app still cannot find your network, please contact our support team.







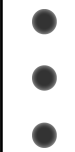
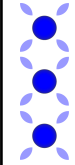
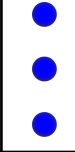
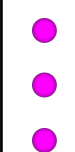

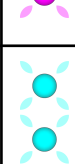
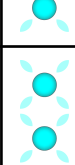
Once the Wi-Fi connection is successful, the 3 lights on the charging dock will be steady green and you can now use your Microphone Kit on the new Wi-Fi network.



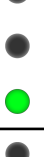

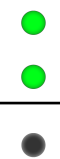



# TROUBLESHOOTING

## Legend of charging dock lights

Consult the chart below for the meaning of the colours and patterns of the charging dock lights, they are grouped by colour.













Lights	Status	Description
	<b>Off.</b>	The charging dock is off.
	<b>Bluetooth active</b>	The charging dock is waiting for a Bluetooth (BLE) connection to a smart device (phone or tablet). This mode can be activated via double-click or is automatically triggered if no Wi-Fi connections are known / nearby.
	<b>Bluetooth connected</b>	The charging dock is successfully connected to a smart device (phone or tablet) via Bluetooth. Via Bluetooth the Wi-Fi credentials can be transferred securely.
	<b>Software Update</b>	The Microphone Kit is downloading and installing a software update. Leave the microphones docked, plug the power cable and wait until the update is finished. When finished, the charging kit turns on to 'Ready for use' automatically. This takes 5-15 minutes depending on your internet speed.
	<b>Failed to update</b>	An error occurred in downloading or installing the software update. Please ensure a stable internet connection, leave the microphones docked and plug the power cable. Re-try to receive the update by turning the charging dock off and back on. If it keeps failing, please contact <a href="mailto:support@speak-see.com">support@speak-see.com</a> .
	<b>Factory reset Initiated</b>	A factory reset has been manually triggered by holding the power button for 10 seconds while turning on.
	<b>Resetting to factory settings</b>	Erasing all user data, including: Wi-Fi credentials, logs, paired microphones, speaker names etc.







	1 blink of all 3 lights in green	<b>Turn on initiated</b>	The power button is pressed and the charging dock is turned on.
	All 3 lights are steady green.	<b>Ready for use</b> The charging dock is ready to stream audio to the Speaksee cloud service.	The battery is between 70-100%.
	The top light is off. The middle and bottom light are steady green.		The battery is between 40-69%.
	The top and middle light are off. The bottom light is steady green.		The battery is between 15-39%.
	The top and middle light are off. The bottom light is alternating between green and red (3 seconds green, 150 ms red).		Battery will be drained soon, place the microphones back on the charging dock. The battery is between 10-14%.
	All 3 lights are steady green.		<b>Charging while on</b> The charging dock is charging (connected to a power supply) and ready to stream audio to the Speaksee cloud service.
	The top light is blinking green (1 second on, 1 second off). The middle and bottom light are steady green.	Charging the battery between 70-99%.	
	The top light is off. The middle light is blinking green (1 second on, 1 second off) and the bottom light is steady green.	Charging the battery between 40-69%.	
	The top and middle light are off. The bottom light is blinking green (1 second on, 1 second off).	Charging the battery between 0-39% .	
	All 3 lights are rapidly blinking orange (0.3 seconds on, 0.3 seconds off).	<b>Connection lost</b>	

	<p>All 3 lights are slowly blinking green (2 seconds on, 1 second off).</p>	<p><b>Booting up</b></p>	<p>The charging dock is turning on, connecting to Wi-Fi and checking for updates. This takes about 30 seconds, or longer with multiple Wi-Fi networks.</p>
	<p>All 3 lights are steady white.</p>		<p>The charging dock is fully charged.</p>
	<p>The top light is blinking white (1 second on, 1 second off). The middle and bottom light are steady white.</p>	<p><b>Charging while off</b></p>	<p>The charging dock is charging and the battery is between 70-99%.</p>
	<p>The top light is off. The middle light is blinking white (1 second on, 1 second off) and the bottom light is steady white.</p>	<p>The charging dock is charging (connected to a power supply) while being off.</p>	<p>The charging dock is charging and the battery is between 40-69%.</p>
	<p>The top and middle light are off. The bottom light is blinking white (1 second on, 1 second off).</p>		<p>The charging dock is charging and the battery is between 0-39%</p>
	<p>The top and middle light remain off. 1 shot of the bottom light in red.</p>	<p><b>Battery empty</b></p>	<p>The battery is too low to turn on, when clicking the power button the charging dock remains off / in standby. Please charge for at least 15 minutes.</p>
	<p>The top and middle light are off. The bottom light rapidly blinks in red (0.3 seconds on, 0.3 seconds off).</p>	<p><b>Battery drained</b></p>	<p>The charging dock is turned off to shipmode. The battery is below 10%.</p>
	<p>All 3 lights are rapidly alternating between red and white (0.3 seconds red, 0.3 seconds white).</p>	<p><b>Error signal</b></p>	<p>An error occurred or the charging dock overheated. Please try to turn it off and on again. If the error keeps occurring please contact <a href="mailto:support@speak-see.com">support@speak-see.com</a>.</p>
	<p>All 3 lights blink red</p>	<p><b>Turn off initiated</b></p>	<p>Full turn off has been manually triggered by holding the power button.</p>





## Legend of the microphone light

Consult the chart below for the meaning of the colours and patterns of the microphone light, they are grouped by colour.

Status	Description		
<b>Off</b>	The microphone is turned off.		light light is off.
<b>Not paired</b>	The microphone is turned on and waiting to be paired to a charging dock.		Slowly blinking blue (2 seconds on, 1 second off).
<b>Pairing confirmation</b>	The microphone is successfully paired to a charging dock by docking it while the charging dock is on. Make sure a factory reset is performed on the charging dock beforehand.		One blink in blue.
<b>Updating</b>	The Microphone Kit is downloading and installing an update. Leave the microphones docked until the update is finished, indicated by the charging dock turning off.		Steady fuchsia (pink/purple).
<b>Failed to update</b>	An error occurred in downloading or installing the update. Please ensure a stable internet connection and leave the microphones docked. If it keeps failing, please contact <a href="mailto:support@speak-see.com">support@speak-see.com</a> .		Rapidly blinking fuchsia (0.3 seconds on, 0.3 seconds off).
<b>Turned on</b>	The power button is pressed and the microphone is turned on.		One blink in green.
<b>Ready for streaming</b>	The battery is between 15-100%.		Steady green.
	The microphone is ready to stream audio to the charging dock. Battery will be drained soon, place the microphone back on the charging dock. The battery is between 10-14%.		Alternating between green and red (3 seconds green, 150 ms red).
<b>Booting-up</b>	The microphone is turned on and connecting to the charging dock. This takes about 10 seconds.		Slowly blinking green (2 seconds on, 1 second off).
<b>Charging</b>	The microphone is docked on the charging dock and fully charged.		Off.
	The microphone is charging while being off (in standby). The microphone is charging on the charging dock and the battery is between 0-99%		Steady white.
<b>Docked</b>	The microphone is successfully docked in a charging dock and thereby turned to standby.		One blink in white.

<b>No battery</b>	The battery is too low to turn on, when clicking the power button the microphone remains off.		1 shot in red.
<b>Battery drained</b>	The microphone is turned off because the battery is below 10%.		Rapidly blinking red (0.3 seconds on, 0.3 seconds off).
<b>Fatal error</b>	An error occurred or the microphone overheated. Please try to turn it off and on again. If the error keeps occurring please contact <a href="mailto:support@speak-see.com">support@speak-see.com</a> .		Rapidly alternating between red and white (0.3 seconds red, 0.3 seconds white).
<b>Turn off</b>	The microphone is turned off.		1 flash in red.
<b>Connection lost</b>	The microphone cannot connect to the charging dock. Make sure the charging dock is on and closeby. If it keeps on occurring please contact <a href="mailto:support@speak-see.com">support@speak-see.com</a> .		Rapidly blinking orange (0.3 seconds on, 0.3 seconds off).
<b>Initiated factory reset</b>	Factory reset has been manually triggered by holding the power button for 10 seconds while turning on.		1 shot in turquoise (light blue).
<b>Resetting to factory settings</b>	Erasing all user data, including: logs, paired charging dock etc.		Slowly blinking turquoise (2 seconds on, 1 second off).

## Legend of power button operation

Action	Press	Description		light feedback
<b>Turn on</b>	1 second hold	To turn on the Microphone Kit, hold the power button for 1 second.		The light lights flash green once to confirm turning on.
<b>Turn off</b>	1 second hold	To turn off the Microphone Kit, hold the power button for 1 second NOTE: The microphones automatically switch to standby when placed back in the charging dock.		The light flashes once in red to confirm turning off
<b>Adding a Wi-Fi network</b>	Double click	To add a Wi-Fi network, the bluetooth connection must be re-established with a phone/tablet. Press the power button 2 times in quick succession while the charging dock is on.  NOTE: This only applies to the charging dock.		The light lights slowly start blinking blue.
<b>Factory reset</b>	Press for 10 seconds	Make sure the Microphone Kit is off in standby, then press and hold the power button for at least 10 seconds.		The light lights begin to flash in turquoise.



## Sharing of user logs

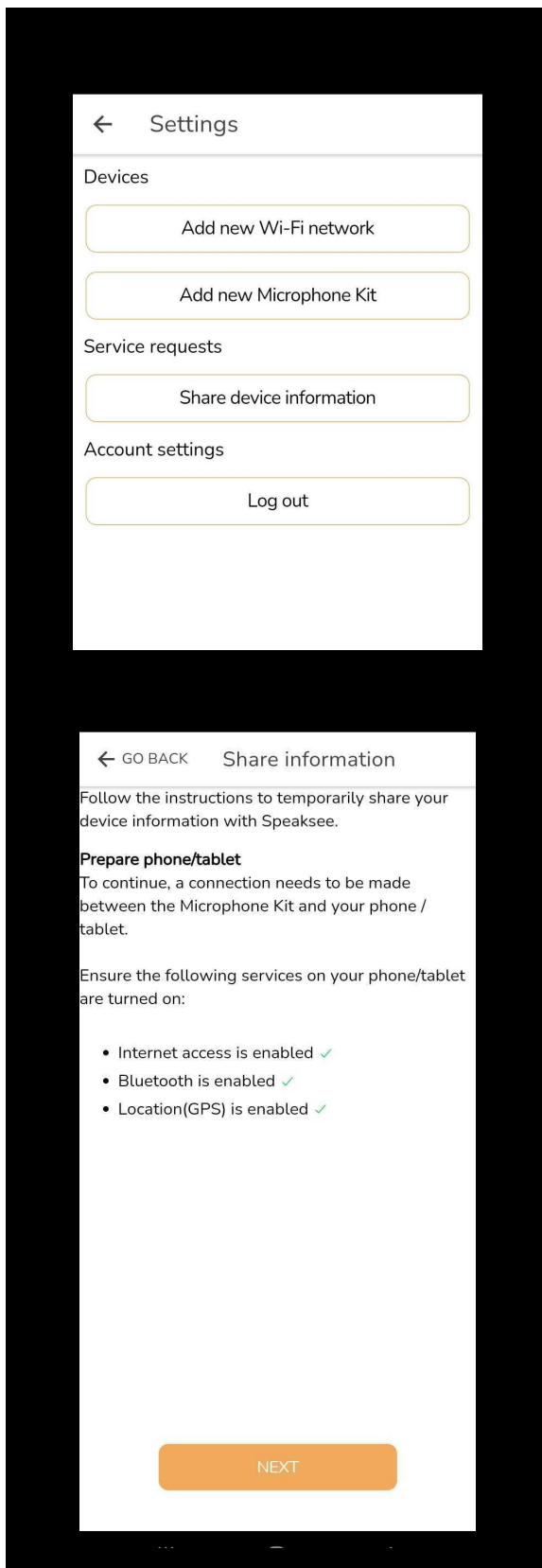

Press the settings button in the menu of the Speaksee app and then press "Share device information".

In order to connect the Microphone Kit to your phone or tablet, Bluetooth must be enabled. **Note: Android users also need to enable their location.**

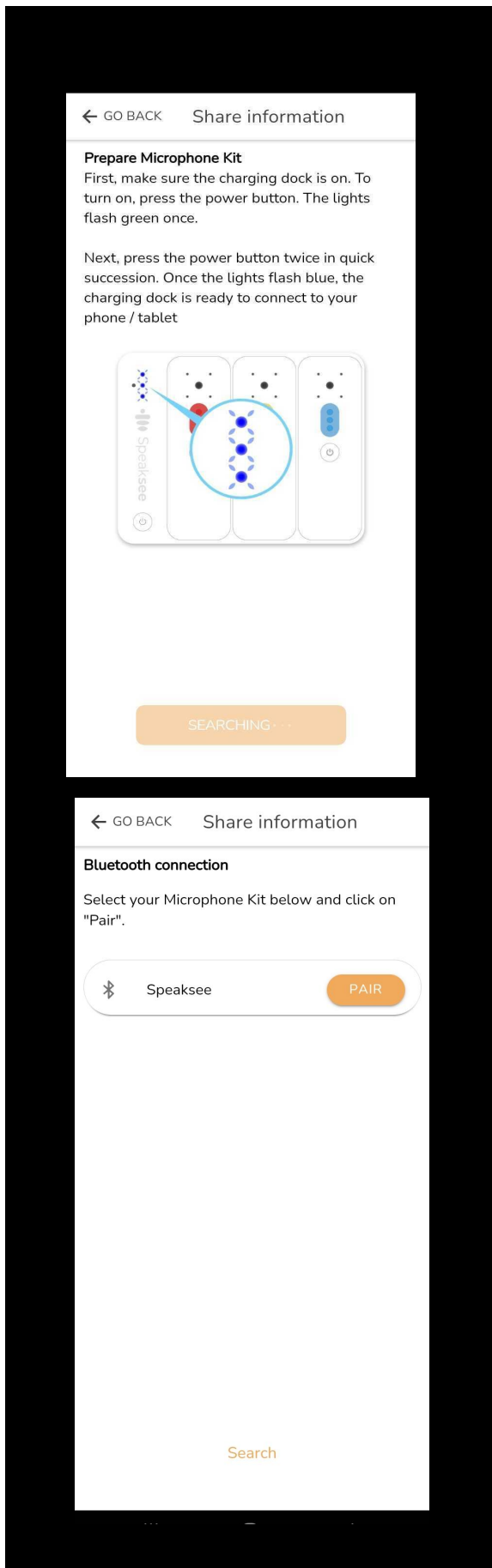

To share the device information, the charging dock must be put manually into Bluetooth mode. First turn on the charging dock. The lights start blinking green. Then double press the on/off button. You will see 3 blue blinking lights. You can now press next.

When your Microphone Kit is found in the app, you can press "pair".

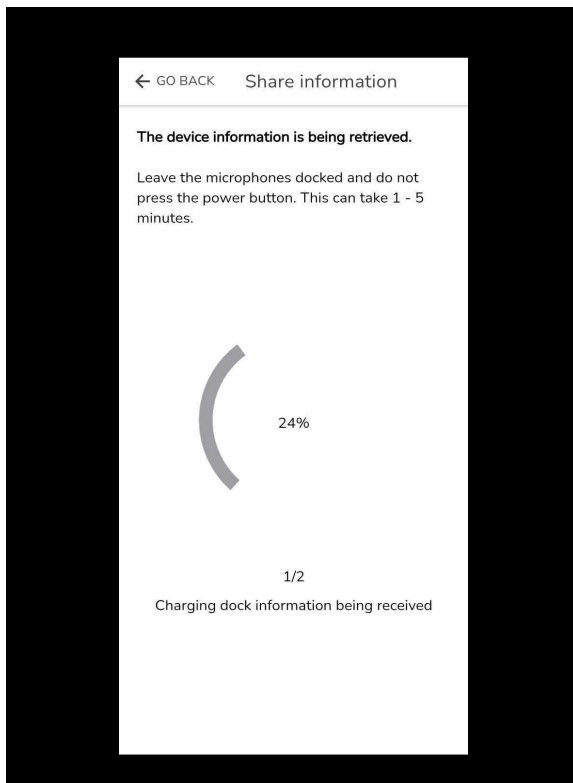

Your Microphone Kit is now sharing the device information to the Speaksee servers. Please note that no personal data such as conversation information is being sent. Do not press any buttons in the app or on the charging dock in this process.

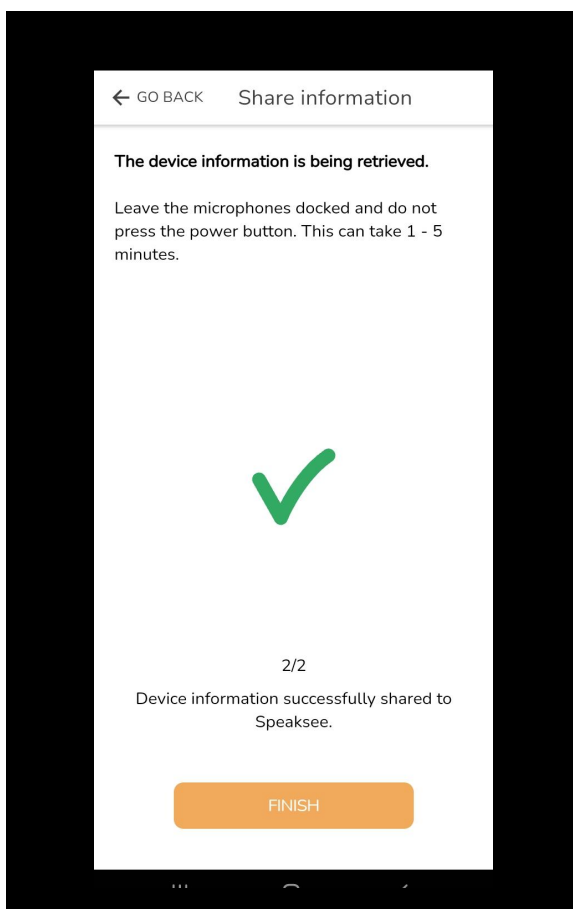

The device information has been shared. You can now press "Finish" and you will be taken back to the settings menu.

## Reset to factory settings

It is possible to erase all user data and information from the Microphone Kit by performing a reset.

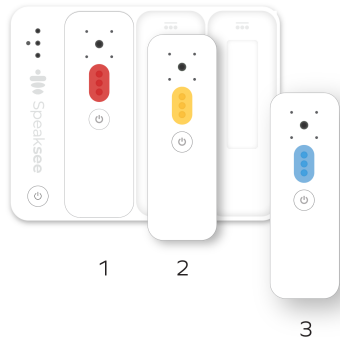

**NOTE: When performing a factory reset, always place the microphones (back) in the charging dock in the following order (from left to right): Red, yellow, blue. As changing speaker colours is not currently supported.**

For both the charging station and the microphones, you can initiate a factory reset by pressing and holding the power button for 15 seconds when turning on (from 'Standby' or 'Fully off' mode). The lights will slowly blink in turquoise. The return to factory settings will only take 15 seconds. After which the device will automatically turn off in standby.

### Data on the Charging dock

Wi-Fi network data, logs, information about paired microphones and colours.

### Data on the microphones

Logs and paired charging stations.

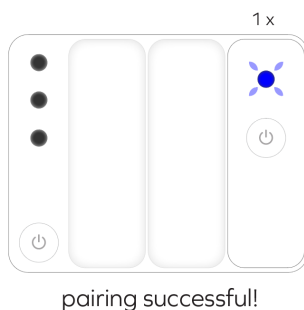
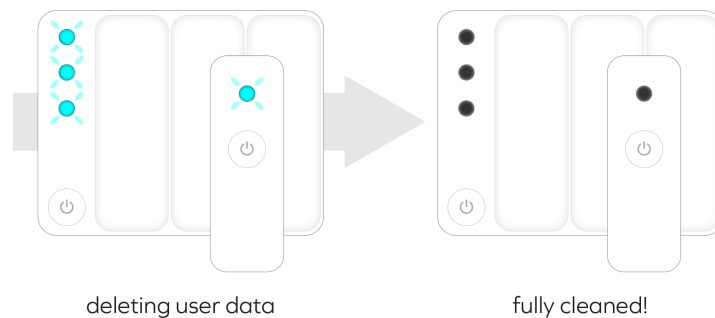

### Reconnecting the charging dock and the microphones

After returning to factory settings, the charging dock and microphones must be reconnected. The microphones are paired by placing them back in the charging dock. The microphone light will blink dark blue once to confirm the pairing.

## TECHNICAL SPECIFICATIONS

	Charging dock	Microphones, 3 pieces total
<b>Outputs</b>	USB-C, Audio, Ethernet	-
<b>Buttons</b>	1 x power button	1 x power button
<b>Sensors</b>	2 x microphone	4 x microphone, with a total focused detection angle of 35 degrees.
<b>LED lights</b>	3 x RGB colour LEDs	1 x RGB colour LED
<b>Power supply</b>	5V, 2A (10W)	-
<b>Battery</b>	1 x 3400 mAh Li-ion	1 x 440 mAh Li-ion
<b>Size</b>	Width: 12.5 cm Height: 9.8 cm Thickness: 2.5 cm	
<b>Weight</b>	256 g	
<b>Colour</b>	White	
<b>In the box</b>	1 x charging dock, 3 x microphone, 9 x colour puck, 3 x neck cord, 1 x international adapter, 1 x USB-C cable, 1 x carry case & documentation. Optional: Wi-Fi hotspot.	
<b>Wireless connections</b>	802.11b/g/n (2.4 / 5 GHz) Single / Dual stream Wi-Fi Bluetooth Low Energy (BLE)	
<b>Requirements</b>	Wi-Fi internet connection or Ethernet cable connection Minimum speed: 1.6 Mbps Upload / 1.0 Mbps download  Speaksee app on a smart device (phone / tablet) with an iOS or Android operating system and Bluetooth Low Energy.	
<b>Certification</b>	The Speaksee Microphone Kit has been tested by SGS laboratories to meet the safety standards of the EU, UK, US, Canada and Australia.	
<b>Sustainability</b>	RoHS conform	

# LEGAL INFORMATION

## Terms and conditions of use



Usage of the Microphone Kit requires acceptance of the The terms and conditions of use, which can be found here: <https://speak-see.com/pages/termsandconditions>





## Privacy policy

Please ensure that everybody who uses the Microphone Kit agrees with their (audio)data being processed in accordance with Speaksee’s privacy policy, which can be found here: <https://speak-see.com/pages/privacy-policy>

## Regulatory information

The Microphone Kit complies with the following regulations:

	<p><b>EU declaration of conformity</b>          Speaksee B.V. declares that this Microphone Kit is in compliance with the essential requirements and other relevant provisions of Directive 2014/53/EU.</p>
	<p><b>FCC statement</b></p> <p><u>15.21:</u> The user is cautioned that changes or modifications not expressly approved by the party responsible for compliance could void the user’s authority to operate this equipment.</p> <p><u>15.105(b):</u> This equipment has been tested and found to comply with the limits for a Class B digital device, pursuant to part 15 of the FCC Rules. These limits are designed to provide reasonable protection against harmful interference in a residential installation. This equipment generates, uses and can radiate radio frequency energy and, if not installed and used in accordance with the instructions, may cause harmful interference to radio communications. However, there is no guarantee that interference will not occur in a particular installation. If this equipment does cause harmful interference to radio or television reception, which can be determined by turning the equipment off and on, the user is encouraged to try to correct the interference by one or more of the following measures:</p> <ul style="list-style-type: none"> <li>• Reorient or relocate the receiving antenna.</li> <li>• Increase the separation between the equipment and receiver.</li> <li>• Connect the equipment into an outlet on a circuit different from that to which the receiver is connected.</li> <li>• Consult the dealer or an experienced radio/TV technician for help.</li> </ul> <p><u>RF radiation exposure statement:</u> This equipment complies with FCC and IC RF radiation exposure limits set forth for an uncontrolled environment. The antenna(s) used for this transmitter must be installed and operated to provide a separation distance of at least 20 cm from all persons and must not be collocated or operating in conjunction with any other antenna or transmitter. Installers must ensure that 20cm separation distance will be maintained between the device (excluding its handset) and users.</p> <p>Cet appareil est conforme aux limites d'exposition au rayonnement RF stipulées par la FCC et IC pour une utilisation dans un environnement non contrôlé. Les antennes utilisées pour cet émetteur doivent être installées et doivent fonctionner à au moins 20 cm de distance des utilisateurs et ne doivent pas être placées près d'autres antennes ou émetteurs ou fonctionner avec ceux-ci. Les installateurs doivent s'assurer qu'une distance de 20 cm sépare l'appareil (à l'exception du combiné) des utilisateurs.</p>

	<p><b>This device complies with Part 15 of the FCC Rules and Industry Canada licence-exempt RSS standard(s).</b>            Operation is subject to the following two conditions: (1) this device may not cause harmful interference, and (2) this device must accept any interference received, including interference that may cause undesired operation.</p> <p>Le présent appareil est conforme aux Partie 15 des règlements de la FCC et CNR d'Industrie Canada applicables aux appareils radio exempts de licence. L'exploitation est autorisée aux deux conditions suivantes: (1) l'appareil ne doit pas produire de brouillage, et (2) l'utilisateur de l'appareil doit accepter tout brouillage radioélectrique subi, même si le brouillage est susceptible d'en compromettre le fonctionnement.</p>
	<p><b>Canadian compliance statement</b>            This Class B digital apparatus complies with Canadian ICES-003.            Cet appareil numérique de la classe B est conforme à la norme NMB-003 du Canada.</p>
	<p><b>UK compliance representative</b>            World Compliance Agency UK Ltd. 71-75 Shelton Street, London, WC2H 9JQ.</p>
	<p><b>Australia compliant</b>            This Microphone Kit complies with EESS (Electrical Equipment Safety System); and ACMA's requirements.</p>
	<p><b>WEEE label</b>            This symbol on the product or its packaging indicates that this product must not be disposed of with your other household waste. Instead, it is your responsibility to dispose of your waste equipment by handing it over to the designated collection point for the recycling of the waste electrical and electronic equipment. The separate collection and recycling of your waste equipment at the time of disposal will help conserve natural resources and ensure that it is recycled in a manner that protects human health and the environment.</p>
	<p><b>SGS energy efficiency</b>            This Microphone Kit meets the relevant standards and specifications, as well as performance requirements.</p>

## Important advice

Please read this full user manual before using this Microphone Kit.

- **Intended use**  
 This Microphone Kit is intended to assist the deaf and hard of hearing during conversation.
- **Preparation**  
 Remove the protective sticker on each of the 3 Microphones before use.
- **Storage**  
 When not in use, store this Microphone Kit in the carry case provided with it.
- **Transportation**  
 Do not subject this Microphone Kit to mechanical shock, such as dropping it.
- **Maintenance**  
 Only use a soft dry cloth to clean this Microphone Kit.

## Safety precautions

Please follow these safety precautions when using the Microphone Kit.

### Electric shock and heat

- Do not expose this Microphone Kit or the power supply to water or extreme conditions. Extreme conditions include, but are not limited to: extreme high or low temperatures and low air pressure at high altitudes.
- Take care when handling the power supply to avoid electric shock. Do not twist or crush the cable. Do not use it if the cable or connectors are torn or damaged.
- To charge this Microphone Kit, only use the power supply provided with it. Do not connect to damaged or unsafe power outlets.
- This Microphone Kit may get hot to the touch during use, this is normal.

### Pacemakers and Other implanted devices

This Microphone Kit contains magnets and components that emit an electromagnetic field and could interfere with pacemakers or other electronic medical devices. Before use, consult your physician or medical device manufacturer about the required minimum safe distance between this Microphone Kit and your medical device.

### Lithium ion battery

The incorporated batteries of the Microphone Kit should not be subjected to the following extreme conditions or user's abuse:

- Replacement of a battery with an incorrect type that can defeat a safeguard.
- Disposal of a battery into fire or a hot oven, or mechanically crushing or cutting of a battery, that can result in an explosion.
- Leaving a battery in an extremely high temperature surrounding environment that can result in an explosion or the leakage of flammable liquid or gas.
- A battery subjected to extremely low air pressure that may result in an explosion or the leakage of flammable liquid or gas.



## CONTACT DETAILS

### We care about you

Please do not hesitate to contact Speaksee with any questions or feedback. We are always looking to improve our products.

Reach out to us via [support@speak-see.com](mailto:support@speak-see.com) or submit our contact form via: <https://speak-see.com/pages/contact>

The answers to the most frequently asked questions can be found on: [speak-see.com/help-center](https://speak-see.com/help-center)

### Social media presence

- Instagram: [https://www.instagram.com/speak\\_see/](https://www.instagram.com/speak_see/)
- Facebook: <https://www.facebook.com/Speaksee>
- Twitter: [https://www.twitter.com/speak\\_see](https://www.twitter.com/speak_see)
- LinkedIn: <https://www.linkedin.com/company/speaksee/>
- YouTube: <https://www.youtube.com/channel/UCQvGf%20iasHyUYZ42RhRsDAMg>

### Office location

Speaksee, Westblaak 7G, 3012 KC Rotterdam, The Netherlands.